



厦门华联半导体科技有限公司
Xiamen Hualian Semiconductor Technology Co., Ltd.

产品规格书

SPECIFICATION

产品名称: 光敏达林顿晶体管输出型光耦合器

DESCRIPTION: Photo Darlington Optocouplers

产品型号: HPC962Ka-2

PART NO.: HPC962Ka-2

拟制 Prepared	审核 Verified	批准 Approved

电 话 Tel: 86-0592-2950777
传 真 Fax: 86-0592-6037471
网 址 Web: www.xmhl.com
地 址 : 厦门市翔安区舂阳南路 189 号
A d d : No.189, Fangyang South Road,
Xiang'an District, Xiamen China.

概述 General

光敏达林顿晶体管输出型光耦合器是将红外 LED 芯片和光敏达林顿晶体管芯片封装在一起，以实现电-光-电转换。产品见图 1。

Photo Darlington Optocouplers which is infrared LED chip and photo Darlington transistor chip are assembled on lead frame, in order to change the electricity-light-electricity. Products shown in Figure 1.



图 1 产品 Figure 1-Product

1 特点 Features

- 达林顿晶体管输出 Darlington transistor output
- 输入、输出端之间绝缘电压高 VISO ≥ 5000Vrms
The isolation voltage between input and output is high VISO ≥ 5000Vrms
- 双列直插式/贴片式 6L 塑料封装 DIP/SOP 6L Plastic Package
- UL 安全认证文件号 UL File No.: E178703
- 静电防护等级：防静电等级 500V（人体模式） ESD grade: 500V（HBM）
- 符合 RoHS 指令最新要求及 REACH 法规最新要求。

Comply with the latest requirements of the RoHS directive and the latest requirements of REACH regulations.

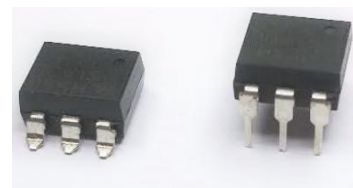
2 应用 Applications

- 数据逻辑转换 Transmission and conversion of digital logic
- 功率控制转换开关 Power control and switch
- 在电路系统中进行电气绝缘和阻抗变换 Electric insulation and impedance conversion between circuits systems

3 极限参数 Absolute Maximum Ratings

表 1 极限参数

Table 1-Absolute Maximum Ratings

Ta=(25±5)°C, RH=45~75%

参数名称 Characteristic		符号 Symbol	额定值 Rating	单位 Unit
输入端 Input	正向电流 Forward Current	I _F	50	mA
	反向电压 Reverse Voltage	V _R	5	V
	耗散功率 Power Dissipation	P _M	75	mW
输出端 output	集电极-发射极反向击穿电压 Collector- Emitter Reverse Breakdown Voltage	V _{(BR)CEO}	300	V
	集电极-发射极反向击穿电压 Emitter-Collector Reverse Breakdown Voltage	V _{(BR)ECO}	0.3	V
	集电极直流电流 Collector Current	I _{CM}	150	mA
	集电极耗散功率 Collector Power Dissipation	P _c	150	mW
结温 Junction Temperature		T _j	100	°C
工作温度 Operating temp.		T _{aop}	-40 ~ +110	°C

贮存温度 Storage temp.		T_{stg}	-55 ~ +125	°C
焊接温度 Soldering Temperature	手工焊 Hand Soldering (5 Sec.)	T_{sld}	350	°C
	回流焊 Reflow Soldering (120 Sec.)		245	
	波峰焊 Wave Soldering (10 Sec.)		270	
功率 Power Dissipation		P_t	250	mW
绝缘电压 Isolation voltage (RH≤60%,交流 1 分钟) (RH≤60%, AC 1min.)		V_{ISO}	5000	V_{rms}

4 光电参数 Opto-Electrical Characteristics

表 2 光电参数

Table 2-Opto-Electrical Characteristics $T_a=(25\pm 5)^\circ\text{C}$, RH=45~75%

参数 Parameters	符号 symbol	测试条件 Test condition	最小值 Min.	典型值 Typ.	最大值 Max.	单位 Unit
输入 Input	正向电压 Forward Voltage	V_F $I_F=10\text{mA}$			1.4	V
	反向电流 Reverse Current	I_R $V_R=5\text{V}$			10	μA
输出 Out-put	集电极-发射极反向击穿电压 Collector-Emitter Reverse Breakdown Voltage	$V_{(BR)CEO}$ $I_C=0.1\text{mA}$	300			V
	发射极-集电极反向击穿电压 Emitter-Collector Reverse Breakdown Voltage	$V_{(BR)ECO}$ $I_E=0.1\text{mA}$	0.3			V
	集电极-发射极反向电流 Collector-Emitter Reverse Current	I_{CEO} $V_{CE}=200\text{V}$			200	nA
耦合特性 Transfer Features	电流传输比 Current Transfer Ratio	CTR $I_F=10\text{mA}$ $V_{CE}=1.5\text{V}$	500			%
	饱和压降 Saturation voltage	$V_{CE(sat)}$ $I_F=1\text{mA}$ $I_C=10\text{mA}$			1.0	V
绝缘特性 Isolation Features	绝缘电压 Isolation Voltage between Input and Output	V_{ISO} $I_{OFF}<0.3\text{mA}$, AC, 60S	5000			V_{rms}
	常温绝缘电阻 Isolation Resistance between Input and Output	R_{ISO} $V=500\text{V}$	10^{12}			Ω
	输入-输出端电容 Capacitance (input to output)	C_S $V_S=0\text{V}$ $f=1\text{MHz}$		0.8		pF
开关特性 On-Off Features	上升时间 Rise Time	t_r $V_{CE}=10\text{V}$ $R_L=100\Omega$		40		μs
	下降时间 Fall Time	t_f $I_C=10\text{mA}$		15		μs
	开启时间 Turn-on Time	t_{on} $V_{CE}=10\text{V}$ $R_L=100\Omega$		50		μs
	关断时间 Turn-off Time	t_{off} $I_C=10\text{mA}$		15		μs

5 电原理图 Schematic Diagram



图 2 电原理图
Figure 2-Schematic

6 外形尺寸图 Dimensions Diagram

7

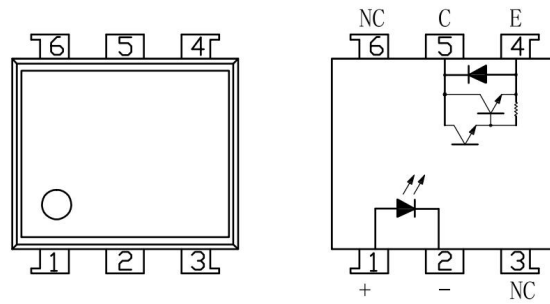

图 3 HPC962Ka-2 外形尺寸
Figure 3- The dimensions of HPC962Ka-2

8 标志 Mark

产品上应有型号、公司商标、生产日期代码、引出端识别标记。例如：HPC962Ka-2 产品印章如图 4。
Print type characters, trade mark and Lot.No.on the Photo Coupler. For example the marking of product HPC962Ka-2 is shown as figure 5.

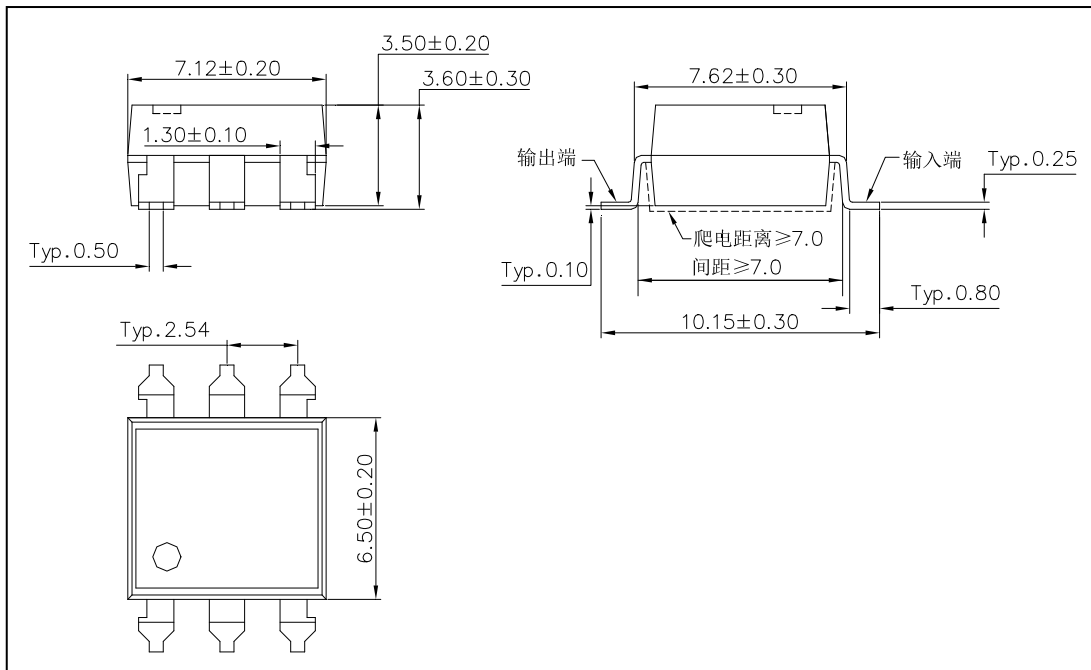

图 4 产品印章
Figure 4- Marking

9 包装方式 Packing

9.1 编带包装 (Tape and reel): 适用于 For HPC962Ka-2。

9.1.1 每卷数量 (Qty/reel): 1000 只 (pcs)。每箱数量 (Qty/ctn): 15000 只 (pcs)。

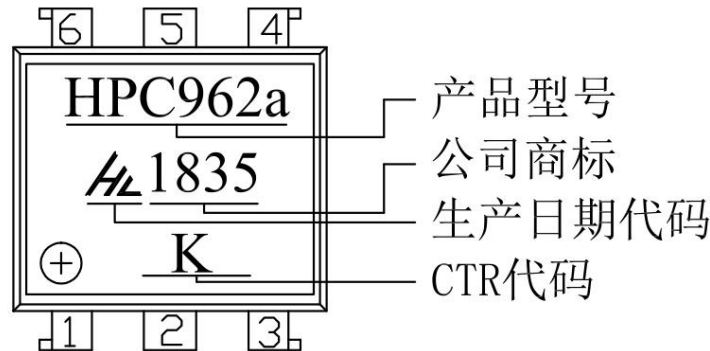
9.1.2 内包装 (Inner packing):

每卷盘 1000 只, 贴合格证 (型号、生产日期代号、检验员代号)。

1000pcs/reel, certificate on reel (model, code of product date, Inspector's code)

9.1.3 外包装(Outer packing):

公司名称、地址、商标、产品型号、数量等标志。

Indication of company name, address, trade mark, model and quantity.

9.1.4 示意图 (Schematic)



图 5 编带包装示意图
Figure 5- Taping Packing Schematic

10 标识 Label

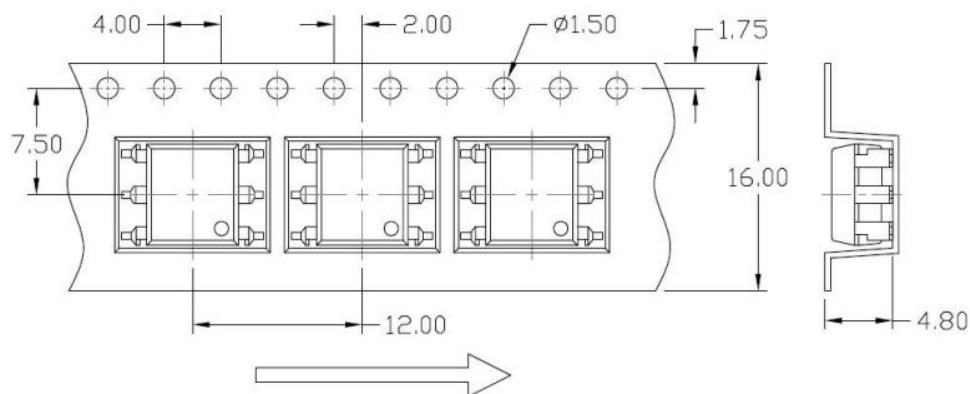

图 6 标识

Figure 6-Label

11 注意事项 Note

11.1.1 推荐贮存温度 Recommend storage Temp.: 0~40°C;

推荐贮存湿度 Recommend storage humidity: <70%;

贮存有效期半年 Storage life: Half of a year.

11.1.2 湿气敏感度等级 3 级。MSL level: MSL 3.

11.2 引脚镀锡厚度: 大于等于 5 μ m, 平均 8 μ m~10 μ m。

Thickness of Sn which plated on lead frame: $\geq 5 \mu\text{m}$, average 8 μm ~10 μm .

11.3 推荐焊接条件 Recommended soldering conditions

11.4 施加在环氧树脂上的温度不要超过最高贮存温度。

Not to apply high temperature exceeding the maximum storage temperature to the epoxy resin.

11.5 在高温下不要对环氧树脂施加压力。

Not to apply any force to the epoxy resin at high temperature.

11.6 焊接过程 Soldering process

1. 在焊接过程中不要对器件施加任何压力。

Not to apply any stress to the component during the soldering process.

2、回流焊 Reflow soldering

1) 推荐锡膏规格 Recommend tin glue specifications:

a) 熔点 Melting temperature: 217°C

b) 组分 Contains: SnAg3Cu0.5

2) 回流焊工序必须在器件冷却至室温后进行。

Never take next process until the component is cooled down to room temperature after reflow.

3) 推荐无铅回流焊接参数, 如下图所示:

The recommended Lead-free reflow soldering profile is following:

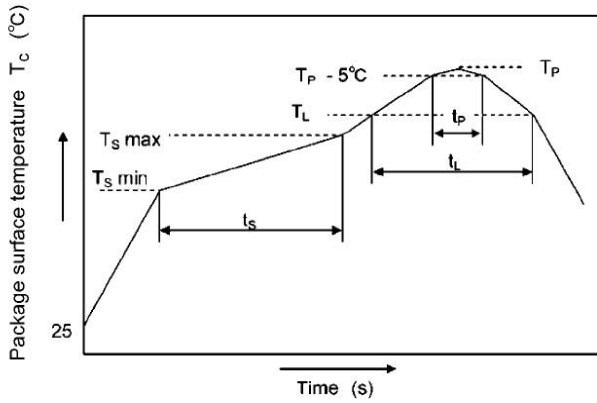

	Symbol	Min	Max	Unit
Preheat temperature	T_s	150	200	°C
Preheat time	t_s	60	120	s
Ramp-up rate (T_L to T_P)			3	°C/s
Liquidus temperature	T_L	217		°C
Time above T_L	t_L	60	150	s
Peak temperature	T_P		260	°C
Time during which T_c is between ($T_P - 5$) and T_P	t_p		30	s
Ramp-down rate (T_P to T_L)			6	°C/s

图 7 回流焊参数

Figure 7-Recommended reflow soldering profile

12 产地 Production Place

12.1 产地 Production Place: 中国厦门 Xiamen China;

12.2 工厂名称 Production NO.: 厦门华联半导体科技有限公司; Xiamen Hualian Semiconductor Technology Co., Ltd.;

12.3 工厂地址 Production Add.: 厦门市翔安区舩阳南路 189 号 No.189, Fangyang South Road, Xiangan District, Xiamen China.

