



厦门华联半导体科技有限公司

Xiamen Hualian Semiconductor Technology Co., Ltd.

---

# 产品规格书

## Specification on Product

---

产品名称：贴片光敏晶体管

DESCRIPTION: SMD Photo Diode

产品型号: HMPTG17T

PART NO.: HMPTG17T

拟制 Prepared	审核 Verified	批准 Approved

电话 Tel: 86-0592-2950777

传真 Fax: 86-0592-6037471

网址 Web: [www.xmhl.com](http://www.xmhl.com)

地址: 厦门市翔安区舂阳南路 189 号

Add: No.189,Fangyang South Road,Xiang'an District,Xiamen China

### 1、概述 (General) :

HMPTG17T 是一款贴片 NPN 硅光敏晶体管, 具有响应速度快、灵敏度高、寿命长、可靠性高等优点, 广泛用作光电开关及红外触控屏中的红外信号探测器。

The HMPTG17T is a NPN Silicon Phototransistor in SMD package, with the advantages of fast response time, high photo sensitivity, long life and high reliability etc. It is widely used in Optical Switch or IR Touch Panel as Infrared light detector.

Products shown in Figure 1.

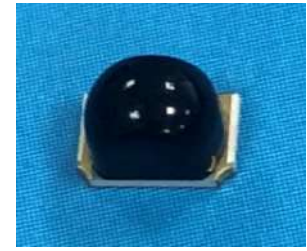


图 1 产品 Figure 1-Product

### 2、特点 (Features) :

- 正贴使用。
- 光感应灵敏度高, 响应速度快。  
High Photo Sensitivity, Fast Response Time.
- 环氧树脂黑色封装 Black Epoxy Package.
- 符合 RoHS 规范。 RoHS Compliant.

### 3、应用 (Applications)

- ◆ 高速红外光探测器 High Speed Infrared light Detector
- ◆ 光开关 Optical Switch

### 4、极限参数 (Maximum Ratings) ( $T_a=25^{\circ}\text{C}$ )

表 1 极限参数

Table 1-Absolute Maximum Ratings

参数名称 Parameters	符号 Symbol	额定值 Rated Value	单位 Unit
集电极-发射极反向击穿电压 Collector Emitter Voltage	$V_{(BR)CEO}$	30	V
发射极-集电极反向击穿电压 Emitter Collector Voltage	$V_{(BR)ECO}$	5	V
集电极电流 Collector Current	$I_{CM}$	20	mA
耗散功率 Power Dissipation	$P_M$	100	mW
工作环境温度 Operating Temperature	$T_{aop}^a$	-25~+85	$^{\circ}\text{C}$
贮存温度 Storage Temperature	$T_{stg}$	-40~+85	$^{\circ}\text{C}$
回流焊温度 (10 秒) Reflow Soldering Temperature (10Sec.)	$T_{sld}$	250	$^{\circ}\text{C}$
手工焊温度 (3 秒) Hand Soldering Temperature (3Sec.)	$T_{sld}$	300	$^{\circ}\text{C}$
<sup>a</sup> 工作环境温度参数符号只在极限参数表中用 $T_{aop}$ 表示, 其他地方用 $T_a$ 表示。 Parameter symbol of Operating Ambiance Temperature uses $T_{aop}$ only in table 1 Absolute Maximum Ratings, and uses $T_a$ at other places.			

### 5、光电参数 Opto-Electrical Characteristics

表 2 光电参数

Table 2-Opto-Electrical Characteristics

T<sub>a</sub>=25°C

参数 Parameter	符号 Symbol	测试条件 Test condition	最小 Min.	典型 Typ.	最大 Max.	单位 Unit
集电极-发射极击穿电压 Collector-Emitter Breakdown Voltage	BV <sub>CEO</sub>	I <sub>C</sub> =0.5mA, E=0mW/cm <sup>2</sup>	30	—	—	V
发射极-集电极击穿电压 Emitter-Collector Breakdown Voltage	BV <sub>ECO</sub>	I <sub>E</sub> =0.1mA, E=0mW/cm <sup>2</sup>	5	—	—	V
集电极发射极饱和压降 Collector-Emitter Saturation Voltage	V <sub>CE(sat)</sub>	I <sub>C</sub> =2.0mA, E=1.0mW/cm <sup>2</sup>	—	—	0.4	V
集电极暗电流 Collector Dark Current	I <sub>D</sub>	V <sub>CE</sub> =10V, E=0mW/cm <sup>2</sup>	—	—	100	nA
集电极光电流 Collector Light Current	I <sub>C</sub>	V <sub>CE</sub> =5V, E=1mW/cm <sup>2</sup> λ=940nm	500	800	—	μA
接收角 View Angle	2θ <sub>1/2</sub>	V <sub>CE</sub> =5V, E=1mW/cm <sup>2</sup> λ=940nm	X	—	90	deg
			Y	—	50	
响应光谱范围 Response Spectrum	λ <sub>0.02</sub>	—	800	—	1100	nm
峰值响应波长 Wavelength of Peak Sensitivity	λ <sub>P</sub>	—	930	940	950	nm
上升时间 Turn-On Time	Tr	V <sub>CE</sub> =5V, I <sub>C</sub> =1mA RL=1000Ω	—	15	—	μs
下降时间 Turn-Off Time	Tf		—	15	—	μs

### 6、外形尺寸 Outline Dimension:

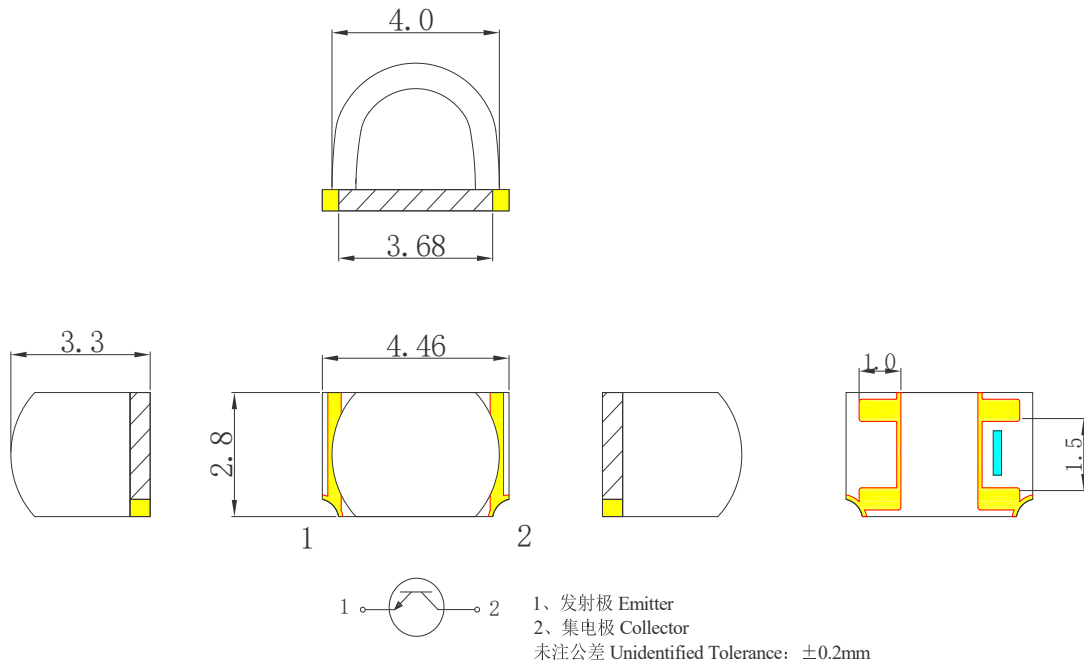


图 2 外形尺寸 Figure 2-Dimensions

7、特性曲线 (Characteristics Curve)

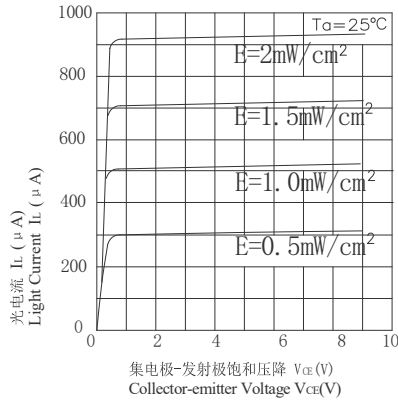


Fig.1 Light Current vs. Collector-emitter Voltage

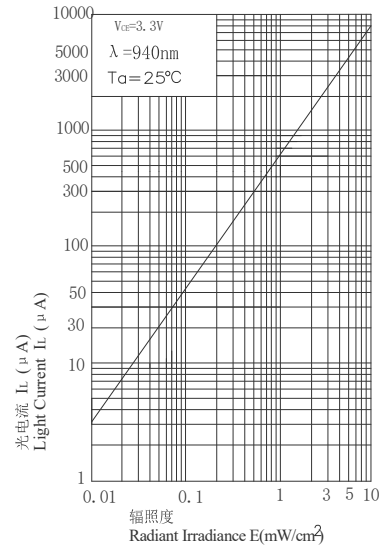


Fig.1 Light Current vs. Irradiance

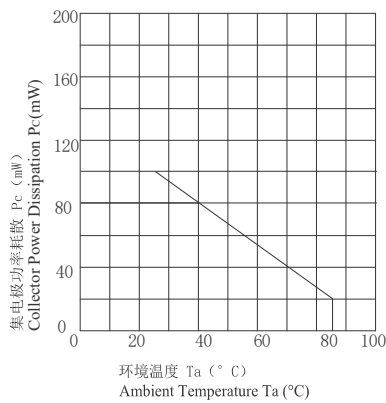


Fig.3 Collector Power Dissipation vs. Ambient Temperature

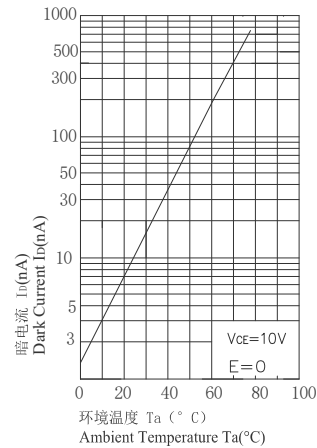


Fig.4 Dark Current vs. Ambient Temperature

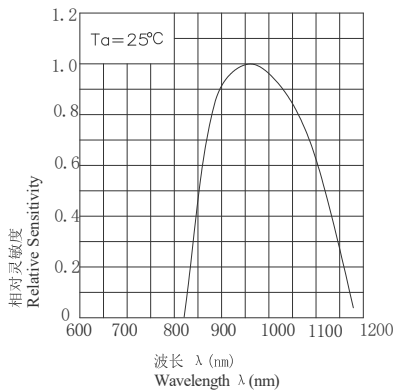


Fig.5 Relative Sensitivity vs. Wavelength

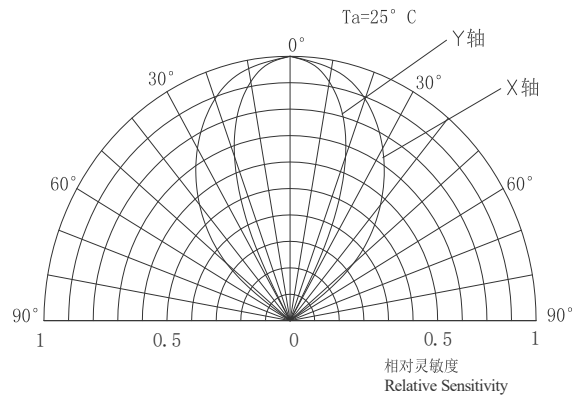


Fig.6 Relative Directional Sensitivity

图 3 特性曲线 Figure 3-Characteristics Curve

## 8、可靠性试验要求(Reliability Test)

表 3 可靠性试验要求 Table 3-Reliability Test

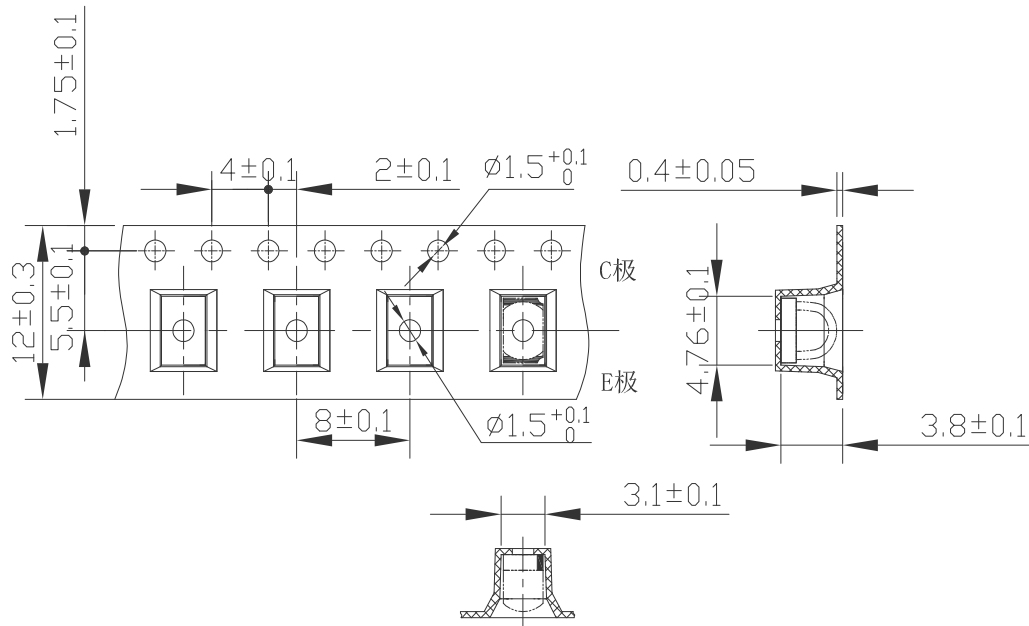
组别	试验项目	试样	试验条件	指标	[Ac, Re]
1	可焊性	16	温度: (245±5) °C 时间: (5±0.5) 秒 浸入离器件环氧本体 (0.5~1.0)mm 处 焊剂: 松香 25%, 酒精 75%	浸润面积≥浸渍面积的 95%	[0, 1]
2	红外回流焊	16	焊接热温度曲线: 参照图 4 红外回流焊温度曲线 焊剂: 松香 25%, 酒精 75%; 1 次	BT 板、环氧体不变色, 无龟裂 $I_c \geq 0.7 I_{c0}(1)$ $I_b \leq 100nA$	[0, 1]
3	快速温度变化及交变湿热	12	快速温度变化: -40°C (10 分) ~ +100°C (10 分) 转移时间: (2~3) 分钟, 10 循环; 恢复 4 小时, 继之于交变湿热试验: 温度 (55±2) °C, 试验周期: 2 天	BT 板、环氧体不变色, 无龟裂 $I_c \geq 0.7 I_{c0}$ $I_b \leq 100nA$	[0, 1]
4	高温高湿贮存	16	温度: (85±2) °C; 湿度: (85±5) %; 时间: 1000 小时;	BT 板、环氧体不变色, 无龟裂 $I_c \geq 0.7 I_{c0}$ $I_b \leq 100nA$	[0, 1]
5	电耐久试验	22	$T_A = RT, V_{CE} = 5V, E_e = 1.0mW/cm^2, \lambda = 940nm$ 1000h	$I_c \geq 0.7 I_{c0}$ $I_b \leq 100nA$	[0, 1]
6	高温贮存	16	温度: 110±2°C, 1000h	BT 板、环氧体不变色, 无龟裂 $I_c \geq 0.7 I_{c0}$ $I_b \leq 100nA$	[0, 1]
	低温贮存	16	温度: -40±3°C, 168h	BT 板、环氧体不变色, 无龟裂 $I_c \geq 0.7 I_{c0}$ $I_b \leq 100nA$	[0, 1]

注: (1)  $I_{c0}$ : 试验前  $I_c$  的测试值。

## 9、包装方式 (Way of Packing)

未注公差: ±0.1 mm。 (All measurements are ±0.1mm unless otherwise indicated.)

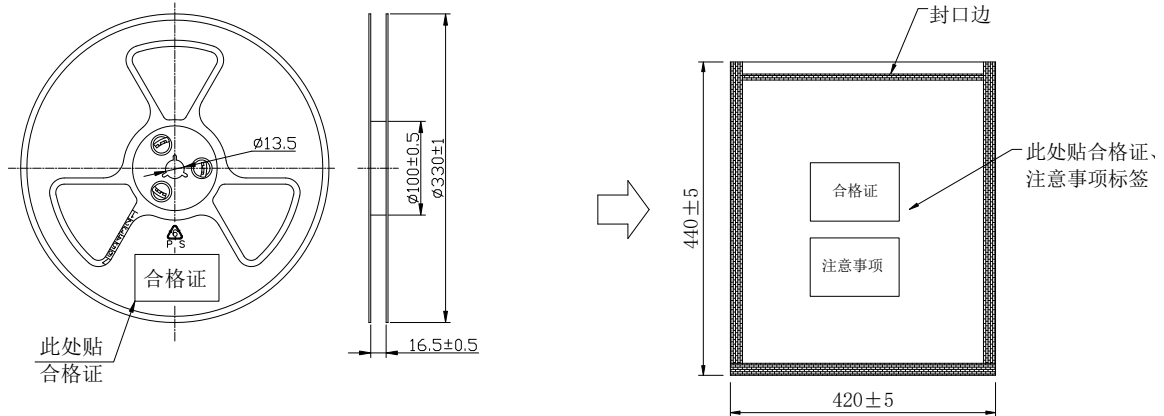
### 9.1 编带规格 Taping



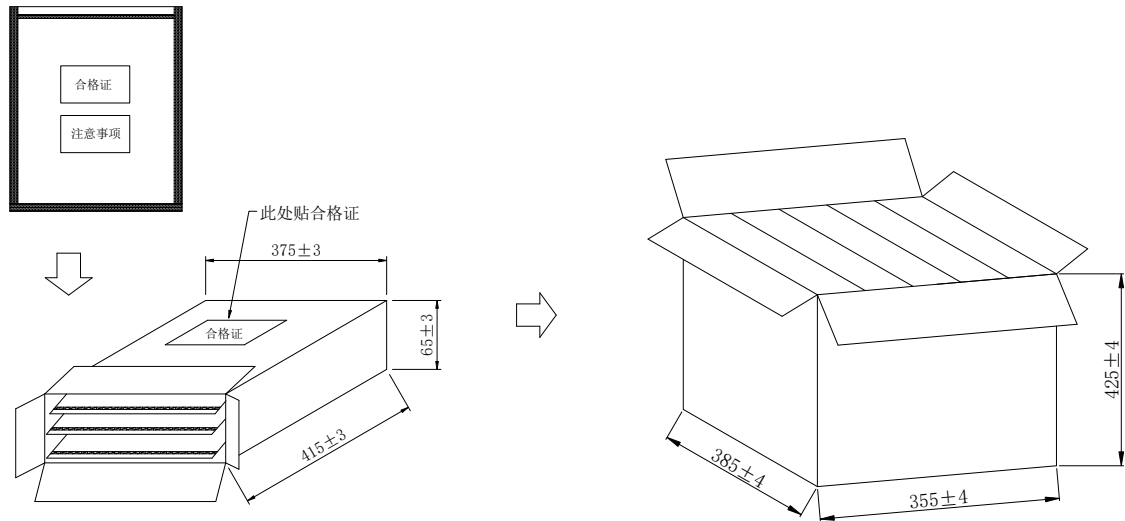
## 9.2 卷盘及铝箔袋规格 Reel and bag

卷盘 Reel: 2000pcs/reel。

防静电铝箔袋 Bag: 2000pcs/bag。



## 9.3 包装纸箱规格 Cardboard box



# 10. 使用注意事项 Precautions for Use

## 10.1 干燥包装 Dry pack

运输及储存中避免吸潮。

Avoid absorbing moisture at any time during transportation or storage.

## 10.2 储存 Storage

1) 请在符合以下要求的环境中储存本产品。It's recommended to store the products in the following conditions:

湿度 Humidity: 60%RH Max.

温度 Temperature: 5°C~30°C.

2) 密封包装搁架时间 12 个月 Shelf life in sealed bag: 12 month at <40°C and <90%RH.

3) 包装袋打开后请在 72 小时内装配使用 (在 ≤30°C/60%RH 的工厂环境下), 或贮存在密闭环境中 (≤20%RH)。After the bag is opened, devices that will be subjected to infrared reflow, or equivalent processing must be: Mounted within 72hrs at factory conditions of ≤30°C/60%RH, or Stored at ≤20%RH with zip-lock sealed.

### 10.3 烘烤 Baking

若产品在未密封的包装袋内搁置超过 72 小时，建议采用 $(120 \pm 3)^\circ\text{C} \times 24$  小时条件进行烘烤后再焊接：  
It's recommended to baking before soldering when the pack is unsealed after 72hrs. The condition is:  $(120 \pm 3)^\circ\text{C} \times 24\text{hrs}$ .

### 10.4 应用（焊接） Application (Soldering)

#### 10.4.1 手工焊接（我们建议应尽量避免采用这种方法）

Manual soldering (We do not recommend this method strongly.)

- 1) 焊锡材料：SnAg0.3Cu0.7。Soldering tin material: SnAg0.3Cu0.7。
- 2) 在手工焊接前先进行烘烤，可避免器件突然受热开裂。To prevent cracking, please bake before manual soldering.
- 3) 引脚焊接最高  $280^\circ\text{C}$  不超过 3 秒，3 次。Lead: Not more than 3 seconds ,3times@Max  $280^\circ\text{C}$ .
- 4) 手工焊接时，请注意避免损伤器件环氧体或引线焊脚。（焊接时不要对器件施加外力）。In manual soldering, take care not to damage the package especially terminal or resin. (Do not give stress to the product when soldering.)
- 5) 已焊接过的器件请不要回用。Do not use again if you remove the soldered product
- 6) 建议使用带温度控制的烙铁。It is recommended using an iron with a temperature control.

#### 11.4.2 回流焊 Reflow soldering

1) 推荐锡膏规格 Recommend tin glue specifications:

- a) 熔点 Melting temperature:  $217^\circ\text{C}$
- b) 组分 Contains: SnAg3Cu0.5

2) 回流焊次工序必须在器件冷却至室温后进行。Never take next process until the component is cooled down to room temperature after reflow.

3) 推荐回流焊接参数（测试于器件硅胶体表面），如下图所示：The recommended reflow soldering profile (measuring on the surface of the LED silicon ) is following:

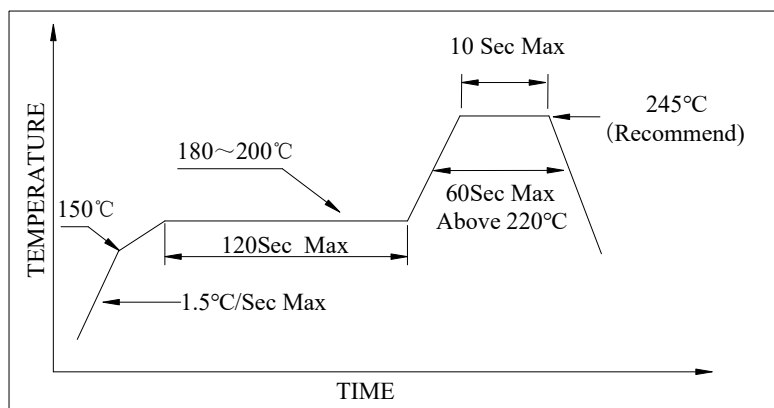


图 4. 红外回流焊温度曲线

### 10.5 清洗 Cleaning

焊接后清洗的条件 The conditions of cleaning after soldering:

- 1) 清洗剂推荐采用乙醇（如 IPA）。An alcohol-based solvent such as Isopropyl Alcohol (IPA) is

recommended.

- 2) 温度×时间 Temperature×Time: <math>< 50^{\circ}\text{C} \times 30\text{sec}</math>, or <math>< 30^{\circ}\text{C} \times 3\text{min}</math>
- 3) 恢复 Curing: <math>100^{\circ}\text{C}</math> max, <math>< 3\text{min}</math>

#### 10.6 吸起及放置注意事项 Cautions of pick and place

- 1) 高温时避免对器件环氧体施加外力。 It should be avoided to load stress on the epoxy during high temperature.
- 2) 避免外界物品导致器件环氧刮伤或擦伤。 Avoid rubbing or scraping the epoxy by any object.
- 3) 静电会导致器件损伤，请确认设备接地良好，有条件可采用离子风机。

Electric-static may cause damage to the component. Please confirm that the equipment is grounding well. Using an ionize fan is recommended.

- 4) 上线自动贴片时，吸嘴(外直径建议 1.5mm 以上)对准产品的 BT 板与环氧体侧面部分。

Automatic working, Sucking mouth(Outer diameter greater than 1.5mm) should be aimed at the side part of BT board and epoxy.

#### 10.7 设计及应用注意事项 Cautions of design and applications

- 1)任何应用必须符合器件的极限参数。

Any application should refer to the specifications of absolute maximum ratings.

- 2)推荐焊盘的尺寸并不适用于所有客户，请参考实际焊接工艺进行调节。

The dimensions of the recommended soldering pattern may not meet every user. Please confirm and study first before designing the soldering pattern in order to obtain the best performance of soldering.

- 3) 避免在装配板上与其他器件相接触。

Do not contact with any component on the assembly board.



## 更改记录表

### Engineering Change Notice-Record

版次 EDITION	更改日期 DATE	主要更改内容 MAIN CONTENT	拟 制 PREPARED	确 认 CHECKED
1.0	2023-01	新版发行 New Edition	兰玉平	段果